



Date :
Événement :
Pilote :

Moteur :
Embrayage : /
Échappement : /
Différentiel :
Carrosserie :

Piste :
Aspect :
Grip :
Conditions :
T° Air :
Pneus avant :
Pneus arrière :

TRAIN AR

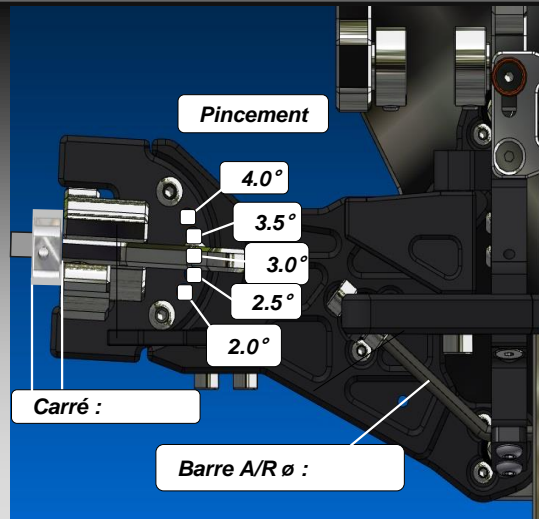
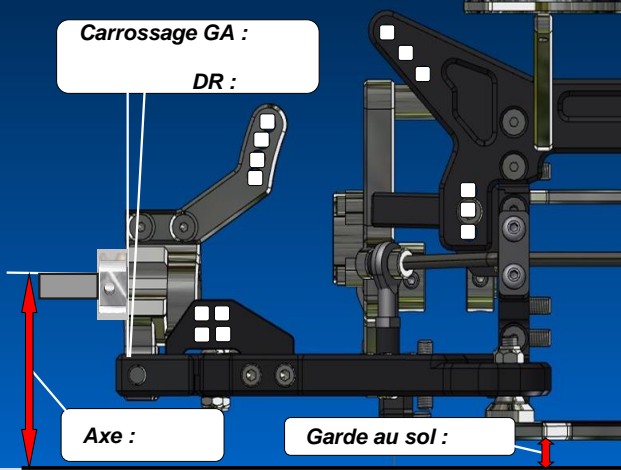

Ressort:

Huile :

Nb trous
Piston :

øTrous
Piston :

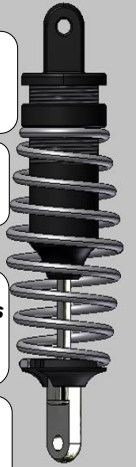

TRAIN AV

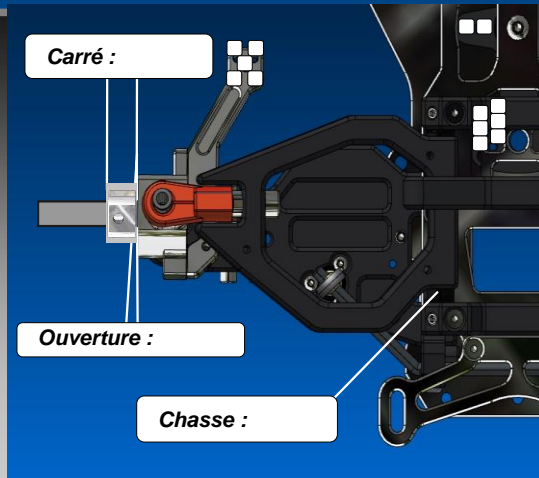
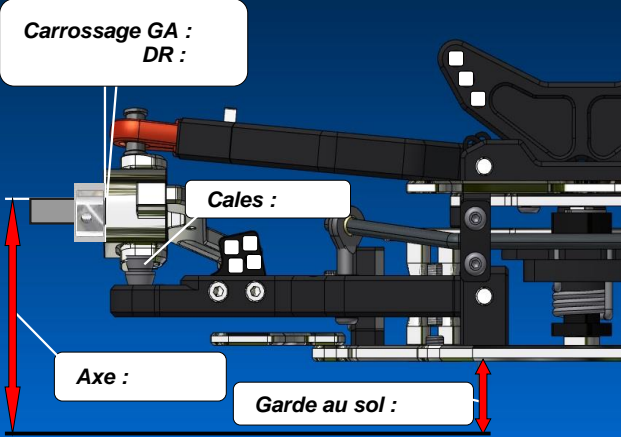

Ressort:

Huile :

Nb trous
Piston :

øTrous
Piston :

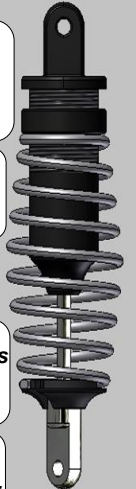

TRANSMISSION

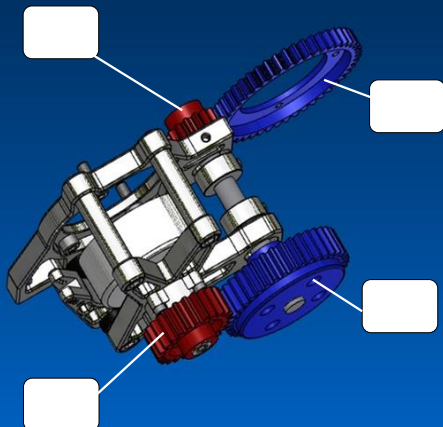

NOTES: